



Nº: LB.TD.TA-EN.W7-8DWI<V3>

Driven Tool Turret Tailstock Lathe

TECHNICAL AGREEMENT

W7-8DWI

2024.12.30



Contents

1.Product Introduction	1
2.Working Conditions	2
3.Precision Standard	2
4.Technical Specifications	3
5.Safety Precautions	6

1.Product Introduction



Figure 1: Appearance Display (Pictures for Reference Only)

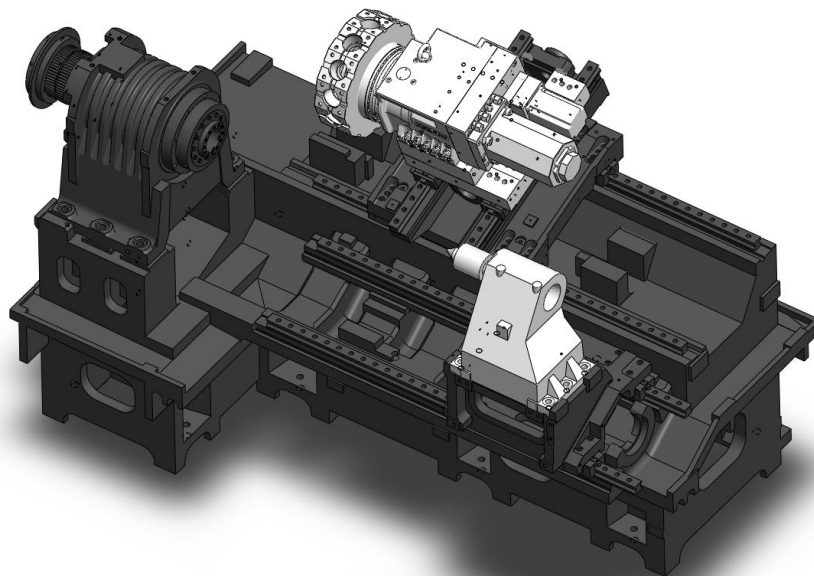

Figure 2: Mechanical Structure Display



2. Working Conditions

- (1) Power supply: AC380V \pm 10%, 50HZ \pm 1HZ three-phase AC.
- (2) Operating temperature: 5°C - 40°C.
- (3) Optimal environmental temperature: 15°C - 25°C.
- (4) Relative humidity: 40 - 75%.

3. Precision Standard

Precision	GB Standard	Company Standard
The Level of Machining Accuracy	IT6	IT6
Machining Roundness Accuracy	0.003mm / Φ 70mm	0.003mm / Φ 70mm
Machining Straightness Accuracy	0.010mm / 150mm	0.010mm / 150mm
Machining Flatness Accuracy	0.008mm / Φ 100mm	0.006mm / Φ 100mm
Machining Roughness Accuracy	Ra1.6 μ m	Ra0.4 μ m Parameter Reference: Material: Al; Spindle Speed: 2200RPM; Feed Rate: 0.06mm/rev; Tool: PCD R0.2
Spindle End Face Runout	0.01mm	0.003mm
Spindle Radial Runout	0.008mm	0.003mm
Axial Positioning Accuracy	X-axis0.016mm	X-axis0.008mm
	Z-axis0.020mm	Z-axis0.008mm
Axial Repeatability Positioning Accuracy	X-axis0.007mm	X-axis0.004mm
	Z-axis0.008mm	Z-axis0.004mm
Turret Indexing Repeatability Positioning Accuracy	Y-Z Direction0.01mm	Y-Z Direction0.006mm
	Z-X Direction0.01mm	Z-X Direction0.006mm

4. Technical Specifications

#	Parameter	Unit	W7-8DWI Driven Tool Turret Tailstock Lathe
1	Max. Turning Diameter	mm	<input type="checkbox"/> $\Phi 350$ (Standard) <input type="checkbox"/> $\Phi 370$ (Spindle Motor Power Needs to Upgrade, Optional)
2	Max. Machining Length	mm	550
3	Max. Swing Diameter	mm	$\Phi 500$
4	Bar Feeding Diameter	mm	$<\Phi 52$
5	Spindle Bore	mm	$\Phi 66$
6	Max. Spindle Speed	RPM	3500
7	X-axis Travel	mm	220
8	Z-axis Travel	mm	600
9	B-axis (Tailstock) Travel	mm	610
10	Rapid Feedrate	m / min	22
11	Max. Driven Tool Speed	RPM	4000
12	Voltage (3phase)	V	$380\pm 10\%$
13	Electric Frequency	Hz	50
14	Power	kW	21
15	Weight	kg	3800
16	Size (Length \times Width \times Height)	mm	$3250 \times 1700 \times 1900$ (Excluding Chip Conveyor)
#	Configuration		
1	CNC Control System	<input type="checkbox"/> FANUC 0I-TF PLUS(3)	
	Main-spindle Rated Power / Torque of the Servo Motor	<input type="checkbox"/> 11kW / 105Nm (Belt Spindle) (Standard) <input type="checkbox"/> 15kW / 143Nm (Belt Spindle) (Optional) <input type="checkbox"/> 15kW / 95Nm (Motor Spindle) (Optional)	
	X-axis Rated Power / Torque of the Servo Motor	1.8kW / 11Nm	
	Z-axis Rated Power / Torque of the Servo Motor	1.8kW / 11Nm	
	Driven Tool Rated Power / Torque of the Servo Motor	2.7kW / 12Nm	

2	\	Brand		Type / Spec	
		<input type="checkbox"/> Taiwan KENTURN Belt Spindle (Standard) <input type="checkbox"/> LBIE Belt Spindle(OEM by HAOZHI) (Optional) <input type="checkbox"/> Guangzhou HAOZHI Motor Spindle (Optional)		<input type="checkbox"/> A2-6 (Standard) <input type="checkbox"/> A2-6(65) (Spindle Bore: $\Phi 79$ mm; Bar Feeding Diameter: $<\Phi 65$) (Optional) <input type="checkbox"/> A2-8 (Spindle Bore: $\Phi 86$ mm; Bar Feeding Diameter: $<\Phi 75$, Match 10inches Chuck;Recommended to Upgrade the Motor) (Optional)	
3	X-axis	Linear Guide Rail	HIWIN / PMI / Rexroth		35 Roller Guide
		Lead Screw	HIWIN / PMI / NSK		32
		Bearing	NSK		20TAC
	Z-axis	Linear Guide Rail	HIWIN / PMI / Rexroth		35 Roller Guide
		Lead Screw	HIWIN / PMI / NSK		32
		Bearing	NSK		20TAC
4	Tool Carrier Form	Turret	Brand	<input type="checkbox"/> Taiwan TCSM (Standard)	<input type="checkbox"/> Taiwan GPM (Optional)
			Driving Type	Servo Motor	
			Locking Type	Hydraulic Locking	
			Model / Station	<input type="checkbox"/> BMT55-12 (Standard) <input type="checkbox"/> BMT45-15 (Optional)	BMT-12 (Max. Driven Tool Speed: 6000; Indexing to 24 Stations)
5	Tailstock Form		Hydraulic Tailstock		
6	Lubrication Form		Grease Lubrication		
7	Hydraulic System		Standard		
8	Fixture		<input type="checkbox"/> Taiwan JIAHE Hydraulic Chuck (8inch) (Standard) <input type="checkbox"/> TGT Collect Chuck (52) (Optional)		
9	Coolant Pump Power		<input type="checkbox"/> 5Bar (Standard)	<input type="checkbox"/> 50Bar (Optional)	
10	Main Electrical Components Brand		Schneider		
11	Chip Conveyor		Included		
12	Electronic Door Lock		Standard		
13	Fixed Tool Holder		Type	Spec	Qty
			Boring Tool Holder	$\Phi 32$	3

		Outer Diameter Turning Tool	25*25	3
		End Face Turning Tool Holder	25*25	1
		<input type="checkbox"/> Optional	7 Included for Any Type (Extra Available)	
14	Driven Tool Holder	Spec	Qty	
		0°	1pcs	
		90° Unidirection	1pcs	
		<input type="checkbox"/> Optional		
15	Other Accessories	Item	Qty	
		Chuck Draw Tube	1pcs	
		Foot Switch	1set	
		Water Tank	1set	
		Installation Tool	1set	
		Machine Foot	9pcs	
16	System Operation Manual	E-manual		
17	Machine Tool Instruction Manual	E-manual		
18	Optional	<input type="checkbox"/> Renishaw Tool Setter		
		<input type="checkbox"/> Automatic Catcher		
		<input type="checkbox"/> Oil Mist Collector		
		<input type="checkbox"/> Automatic Door		
		<input type="checkbox"/> Collision Avoidance System		
		<input type="checkbox"/> Machine IoT Remote Monitoring		

5.Safety Precautions

(1) Always follow the manufacturer's guidelines and instructions for safe operation.

(2) Ensure proper training and qualification of personnel operating the machine tool.

(3) Use appropriate personal protective equipment (PPE) as required.

(4) Regularly inspect and maintain the machine tool to ensure its optimal functioning.

(5) Keep the work area clean and organized to prevent accidents or injuries.

This technical description provides an overview of the key features, capabilities, specifications, and safety precautions associated with the Machine Tool. It serves as a useful reference for understanding the machine's functionality and characteristics in technical documentation.