



№: LB.TD.TA-EN.XL2-8TW<V1>

Servo Turret Hydraulic Tailstock Lathe

TECHNICAL AGREEMENT

XL2-8TW

2024.12.30



Contents

1.Product Introduction	1
2.Working Conditions	2
3.Precision Standard	2
4.Technical Specifications	3
5.Safety Precautions	6



1. Product Introduction



Figure 1: Appearance Display (Pictures for Reference Only)

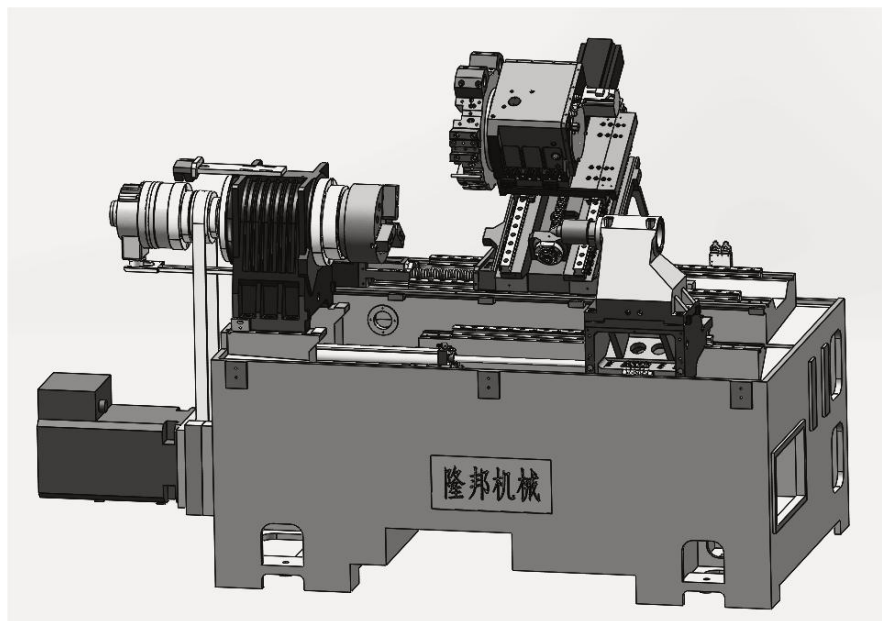

Figure 2: Mechanical Structure Display



2. Working Conditions

- (1) Power supply: AC380V \pm 10%, 50HZ \pm 1HZ three-phase AC.
- (2) Operating temperature: 5°C - 40°C.
- (3) Optimal environmental temperature: 15°C - 25°C.
- (4) Relative humidity: 40 - 75%.

3. Precision Standard

Precision	GB Standard	Company Standard
The Level of Machining Accuracy	IT6	IT6
Machining Roundness Accuracy	0.003mm / Φ 70mm	0.003mm / Φ 70mm
Machining Straightness Accuracy	0.010mm / 150mm	0.010mm / 150mm
Machining Flatness Accuracy	0.008mm / Φ 100mm	0.006mm / Φ 100mm
Machining Roughness Accuracy	Ra1.6 μ m	Ra0.4 μ m Parameter Reference: Material: Al; Spindle Speed: 2200RPM; Feed Rate: 0.06mm/rev; Tool: PCD R0.2
Spindle End Face Runout	0.01mm	0.003mm
Spindle Radial Runout	0.008mm	0.003mm
Axial Positioning Accuracy	X-axis0.016mm	X-axis0.008mm
	Z-axis0.020mm	Z-axis0.008mm
Axial Repeatability Positioning Accuracy	X-axis0.007mm	X-axis0.004mm
	Z-axis0.008mm	Z-axis0.004mm
Turret Indexing Repeatability Positioning Accuracy	Y-Z Direction0.01mm	Y-Z Direction0.006mm
	Z-X Direction0.01mm	Z-X Direction0.006mm



4. Technical Specifications

#	Parameter	Unit	XL2-8TW Servo Turret Hydraulic Tailstock Lathe
1	Max. Turning Diameter	mm	Φ420
2	Max. Machining Length	mm	500
3	Max. Swing Diameter	mm	Φ560
4	Bar Feeding Diameter	mm	<Φ52
5	Spindle Bore	mm	Φ66
6	Max. Spindle Speed	RPM	3500
7	X-axis Travel	mm	240
8	Z-axis Travel	mm	500
9	Tailstock Travel	mm	500
11	Rapid Feedrate	m / min	22
12	Voltage (3phase)	V	380±10%
13	Frequency	Hz	50
14	Power	kW	19
15	Weight	kg	3700
16	Size (Length × Width × Height)	mm	2550×1750×1850 (Excluding Chip Conveyor)
#	Configuration		
1	CNC		<input type="checkbox"/> FANUC 0I-TF PLUS(3)
	Spindle Rated Power / Torque of the Servo Motor		<input type="checkbox"/> 11kW / 105Nm (Standard) <input type="checkbox"/> 15kW / 143Nm (Optional)
	X-axis Rated Power / Torque of the Servo Motor		1.8kW / 11Nm
	Z-axis Rated Power / Torque of the Servo Motor		1.8kW / 11Nm
2	\	Brand	Type / Spec
	Spindle	<input type="checkbox"/> LBIE Belt Spindle (OEM by HAOZHI) (Standard) <input type="checkbox"/> Guangzhou HAOZHI Motor Spindle (Optional) <input type="checkbox"/> Taiwan KENTURN Belt Spindle	A2-6

		(Optional)		
3	X-axis	Linear Guide Rail	HIWIN / Rexroth	35Roller Guide
		Lead Screw	PMI / NSK	32
		Bearing	NSK	20TAC
	Z-axis	Linear Guide Rail	HIWIN / Rexroth	35 Roller Guide
		Lead Screw	PMI / NSK	32
		Bearing	NSK	20TAC
4	Tool Carrier Form	Turret	Brand	Xinlong Driven Tool Turret
			Driving Type	Servo Motor
			Locking Type	Hydraulic Locking
			Model / Station	100-12T
5	Tailstock Form	Hydraulic Tailstock		
6	Lubrication Form	Oil Lubrication		
7	Hydraulic System	Standard		
8	Fixture	<input type="checkbox"/> 52 Type Collect Chuck (Standard) <input type="checkbox"/> 8inch Hydraulic Chuck (Optional)		
9	Coolant Pump Power	<input type="checkbox"/> 5Bar (Standard) <input type="checkbox"/> 50Bar(Optional)		
10	Main Electrical Components Brand	Schneider		
11	Electronic Door Lock	Standard		
12	Fixed Tool Holder	Type	Spec	Qty
		Bore Tool Holder	Φ32	2
		Radial Square Tool Holder	25×25	2
		<input type="checkbox"/> Optional	4 Included for Any Type (Extra Available)	
13	Other Accessories	Item	Qty	
		Chuck Draw Tube	1pcs	
		Foot Switch	1set	
		Water Tank	1set	
		Installation Tool	1set	
		Machine Foot	4pcs	

14	System Operation Manual	E-manual
15	Machine Tool Instruction Manual	E-manual
16	Optional	<input type="checkbox"/> Chip Conveyor
		<input type="checkbox"/> Renishaw Tool Setter
		<input type="checkbox"/> Automatic Catcher
		<input type="checkbox"/> Oil Mist Collector
		<input type="checkbox"/> Automatic Door
		<input type="checkbox"/> Collision Avoidance System
		<input type="checkbox"/> Machine IoT Remote Monitoring



5.Safety Precautions

(1) Always follow the manufacturer's guidelines and instructions for safe operation.

(2) Ensure proper training and qualification of personnel operating the machine tool.

(3) Use appropriate personal protective equipment (PPE) as required.

(4) Regularly inspect and maintain the machine tool to ensure its optimal functioning.

(5) Keep the work area clean and organized to prevent accidents or injuries.

This technical description provides an overview of the key features, capabilities, specifications, and safety precautions associated with the Machine Tool. It serves as a useful reference for understanding the machine's functionality and characteristics in technical documentation.